



Bambusa Stix

Specification Guide

Bambusa Stix

Inspired by natural and timeless building techniques to support a modern work environment.

A design led desk and table system inspired by the honest and simplistic construction of bamboo scaffolding. Stix uses extrusions, die castings and steel tubular profiles to create its unique style.

Bambusa Stix

Electric

6 – 9

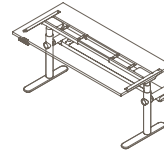

Fixed

10 – 14

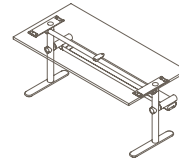

Accessories

15 – 18

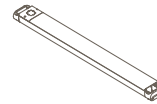

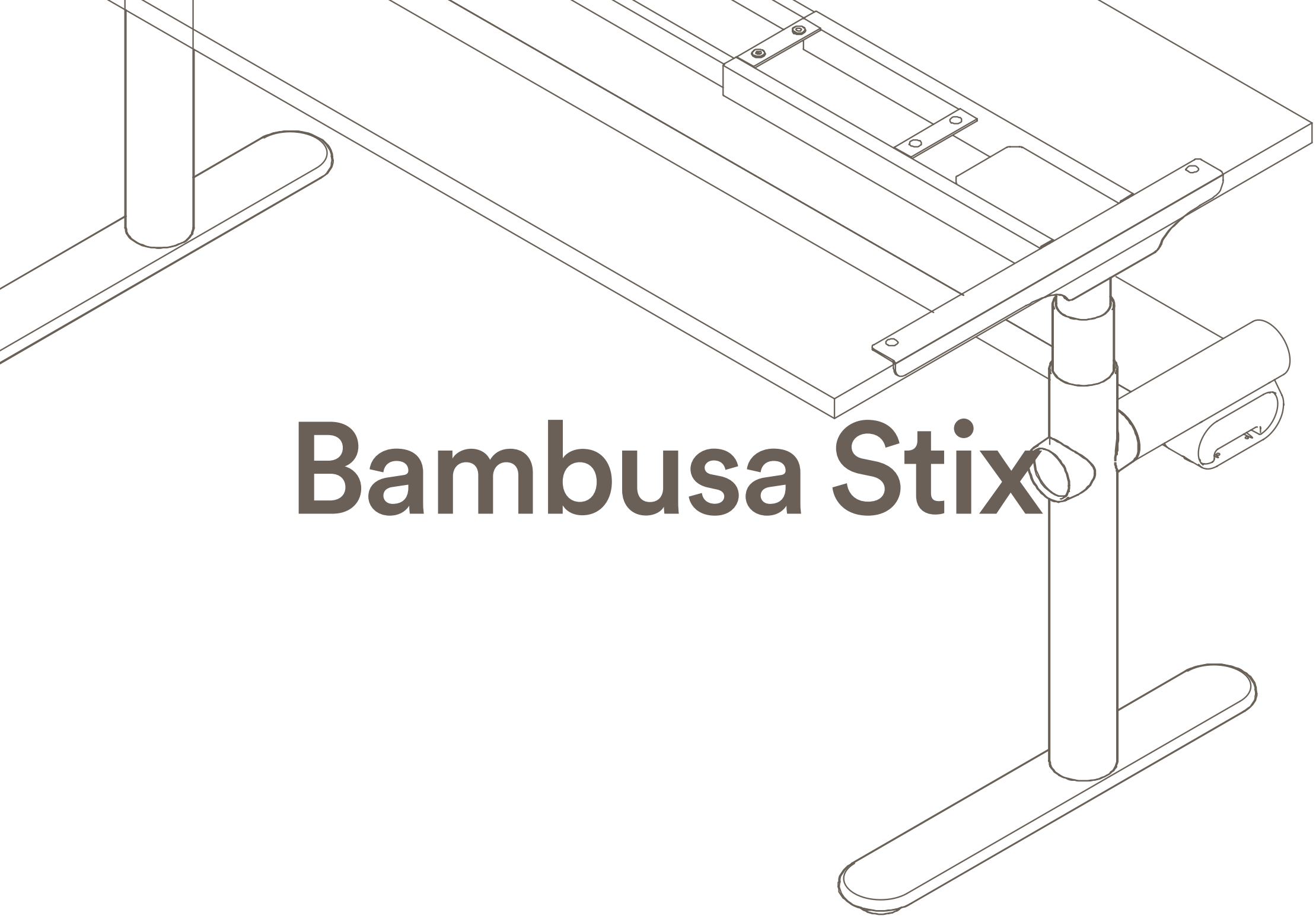

Bambusa Stix

Bambusa Stix Finishes

1. Frame Powdercoat

Stix steel and aluminium frame is available in Noir and Blanc powdercoat.



2. Cable Tray

Our cable management tray is available in Noir and Blanc powdercoat.

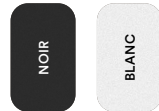

3. Acoustic Screen

Our unique Stix screen is available in Dark Grey and Light Grey acoustic panel. Screen mounts are finished in Noir and Blanc powdercoat.



4. Framed Acoustic Screen

Stix framed screen is available in Dark Grey and Light Grey acoustic panel or upholstered with customer supplied fabric. The aluminium frame is finished in Noir and Blanc powdercoat.

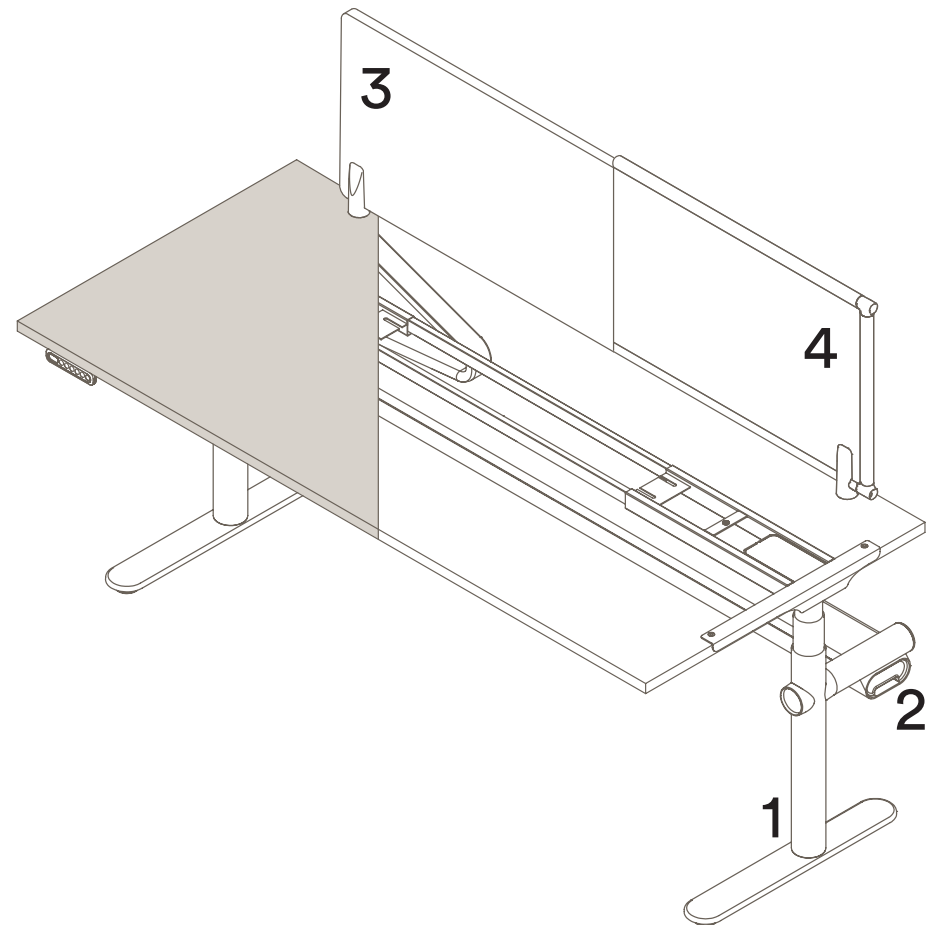

Colours are representative only, please check with your Thinking Works consultant to view samples of any specific colour.

Electric Single Sided

Materials Information

Leg & Foot Finish

Powdercoat Steel Leg & Foot

- a. Noir
- b. Blanc

Frame Finish

Powdercoat Steel

- a. Noir
- b. Blanc

Control Box & Handset Finish

- a. Black

Operating Noise Level

<50Db

Additional Frame Cross-Beam Accessory Rail

Optional for Electric Single Sided 1200-2100mm WP

Optional for Electric 90/120deg 1400-1800mm WP

Required for Electric 90/120deg 1801-2100mm WP

Accessory Rail not required if Cable tray is fitted.

Height Range

600mm to 1250mm to underside of worktop

Travel Speed

35/mm per second

Glide Adjustment

Plus or minus 5mm

Handset

3 programmable height settings with display

Maximum inc. worktop 100kg

Maximum Point Load 30kg

Seats 1

****Worktop length can be up to 2100mm with extra side overhang**

SRE-1001 1pax

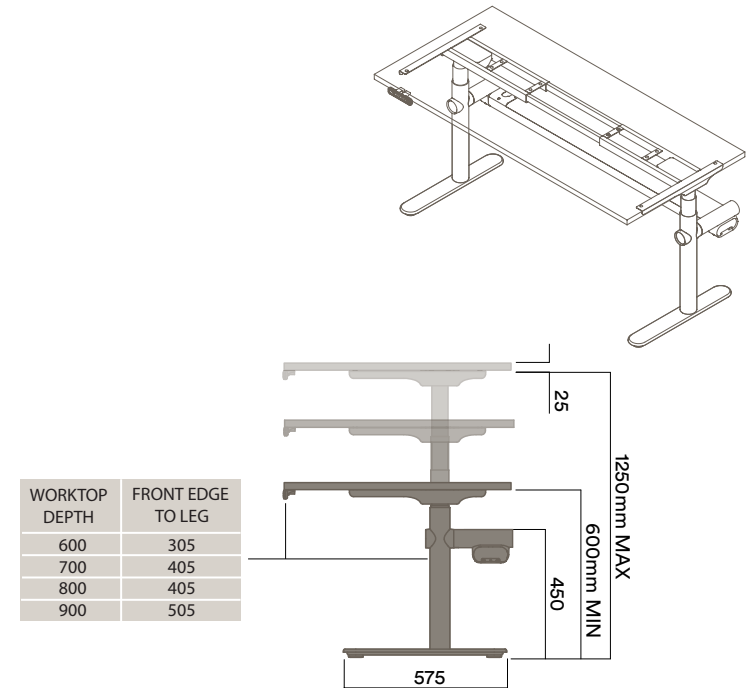
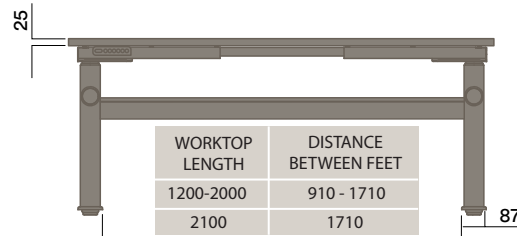
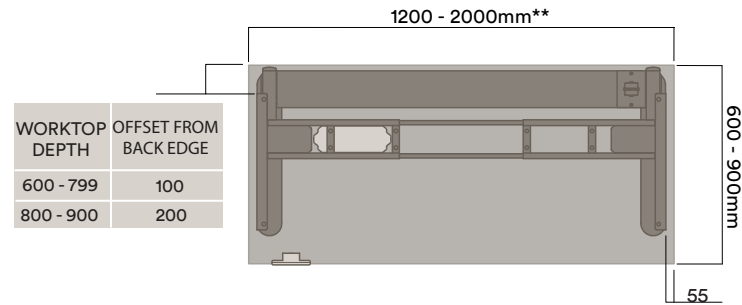

SRE-1090 1pax 90deg

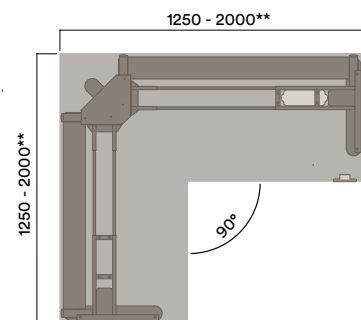

SRE-1120 1pax 120deg

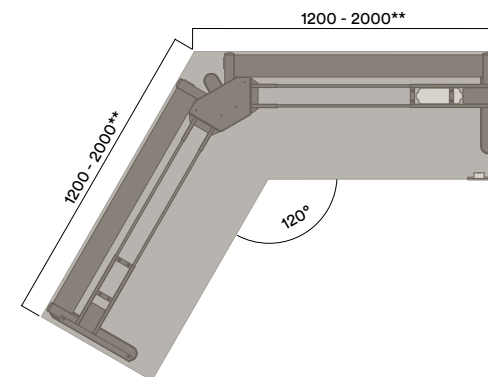

Electric Double Sided

Materials Information

Leg & Foot Finish

Powdercoat Steel Leg & Foot

- a. Noir
- b. Blanc

Frame Finish

Powdercoat Steel

- a. Noir
- b. Blanc

Control Box & Handset Finish

- a. Black

Operating Noise Level

<50Db

Height Range

600mm to 1250mm to underside of worktop

Travel Speed

35/mm per second

Glide Adjustment

Plus or minus 5mm

Handset

3 programmable height settings with electronic display

Maximum inc. worktop 150kg

Maximum Point Load 30kg

Seats 2

*100mm gap required when using rear mounted screens

**Worktop length can be up to 2100mm with extra side overhang

SRE-2002 2pax

H-Frame

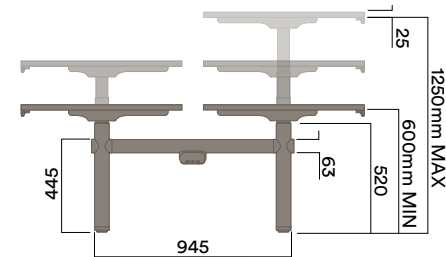
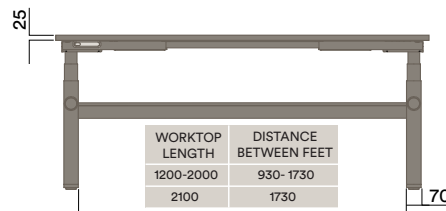
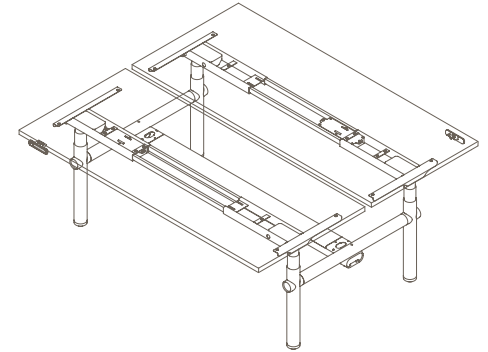
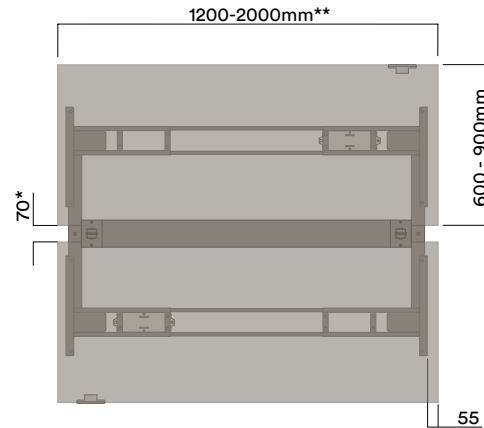

2x SRE-2002

4pax Configuration

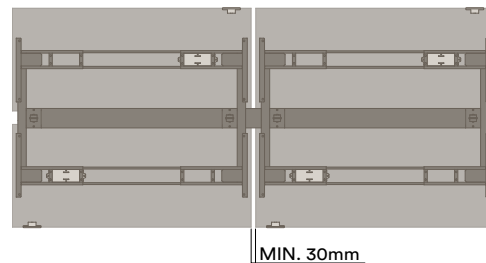

3x SRE-2002

6pax Configuration

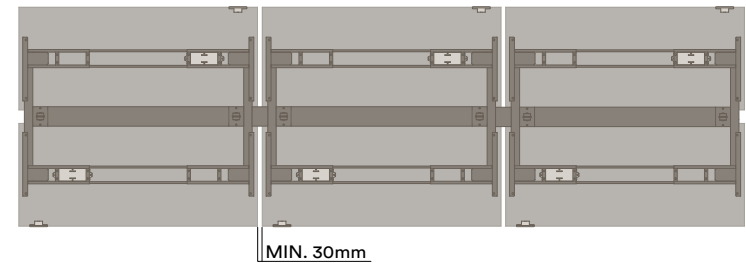

Electric Double Sided

Materials Information

Leg & Foot Finish

Powdercoat Steel Leg & Foot

- a. Noir
- b. Blanc

Frame Finish

Powdercoat Steel

- a. Noir
- b. Blanc

Control Box & Handset Finish

- a. Black

Operating Noise Level

<50Db

Height Range

600mm to 1250mm to underside of worktop

Travel Speed

35/mm per second

Glide Adjustment

Plus or minus 5mm

Handset

3 programmable height settings with electronic display

Maximum inc. worktop 150kg

Maximum Point Load 30kg

Seats 3 - 4

***100mm gap required when using rear mounted screens**

****Worktop length can be up to 2100mm with extra side overhang**

SRE-3120 3pax

120deg H-Frame

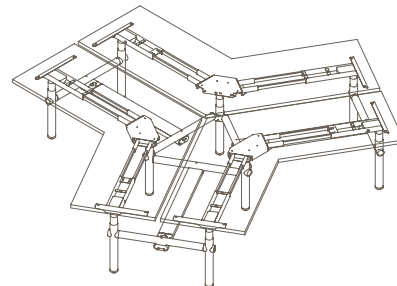
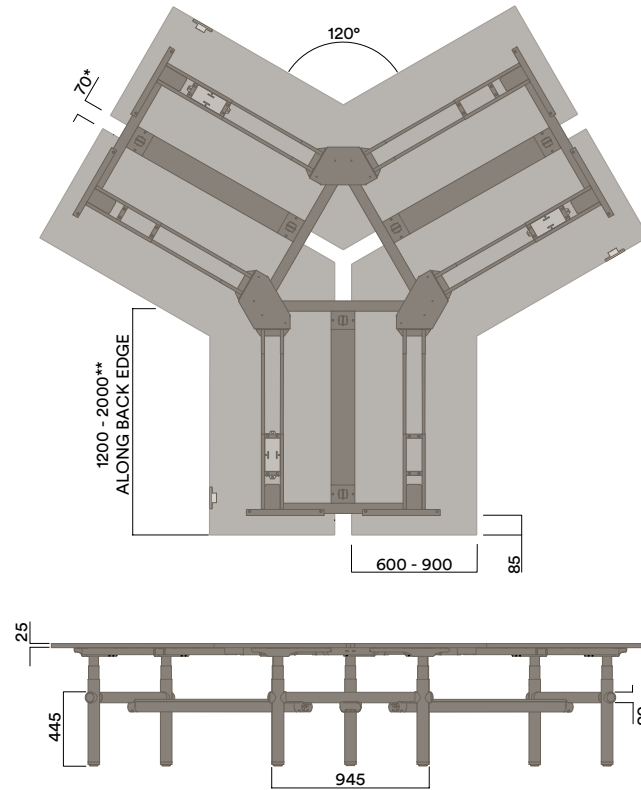

SRE-4090 4pax

90deg H-Frame

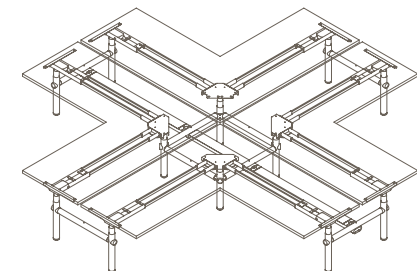
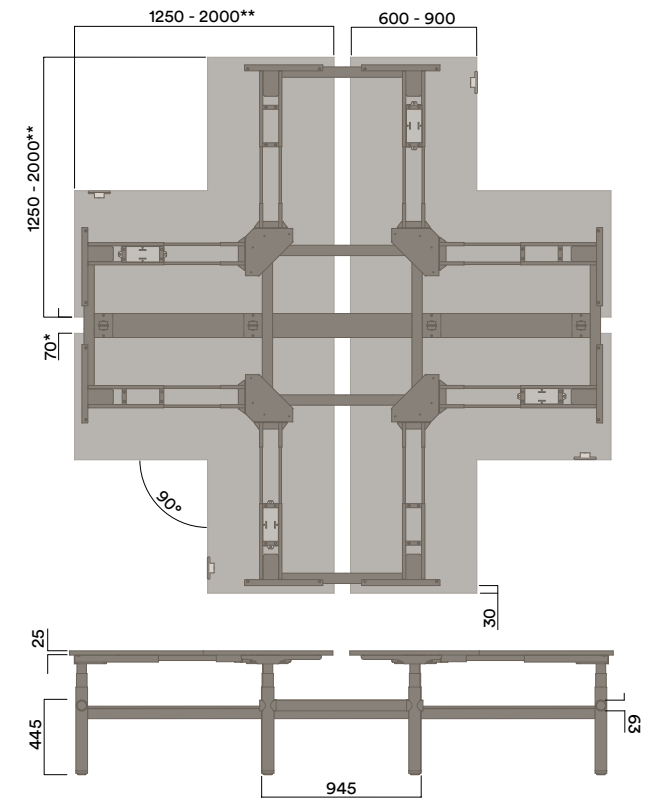

Electric Double Sided

Materials Information

Leg & Foot Finish

Powdercoat Steel Leg & Foot

- a. Noir
- b. Blanc

Frame Finish

Powdercoat Steel

- a. Noir
- b. Blanc

Control Box & Handset Finish

- a. Black

Operating Noise Level

<50Db

Height Range

600mm to 1250mm to underside of worktop

Travel Speed

35/mm per second

Glide Adjustment

Plus or minus 5mm

Handset

3 programmable height settings with electronic display

Maximum inc. worktop	150kg
Maximum Point Load	30kg
Seats	4

***100mm gap required when using rear mounted screens**

SRE-4090-24 4pax

90deg H-Frame

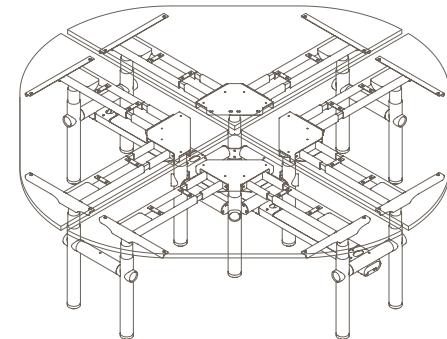
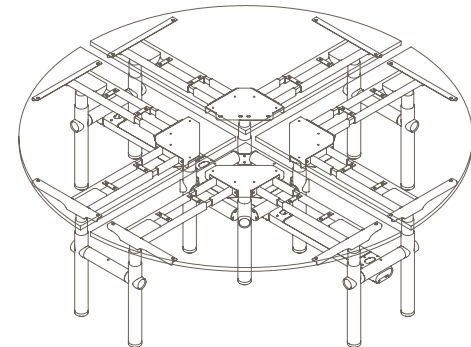
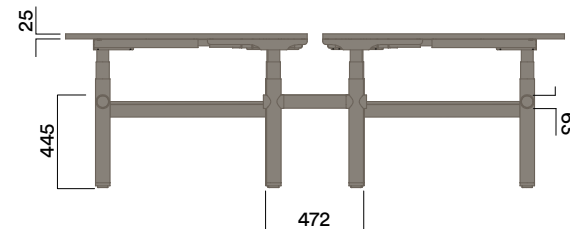
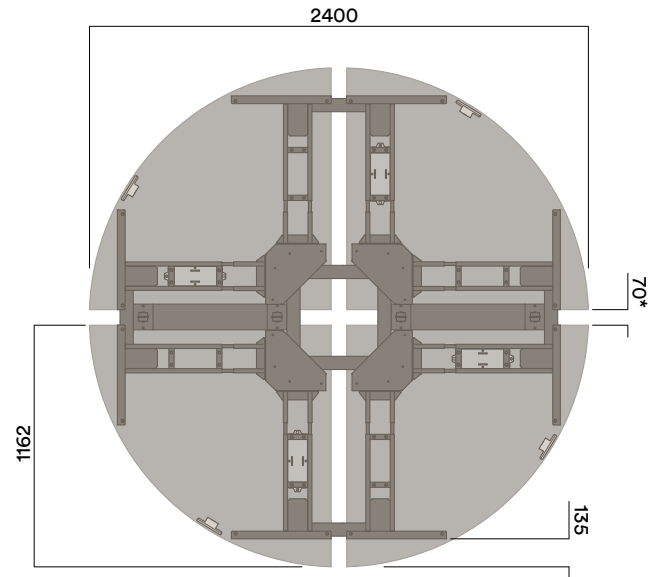

Fixed Single Sided

Materials Information

Leg & Foot Finish

Powdercoat Steel Leg & Foot

- a. Noir
- b. Blanc

Frame Finish

Powdercoat Steel

- a. Noir
- b. Blanc

SRF-1001 1pax

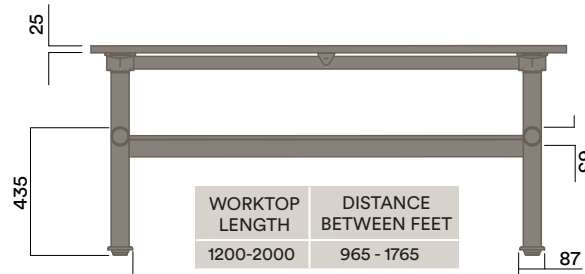
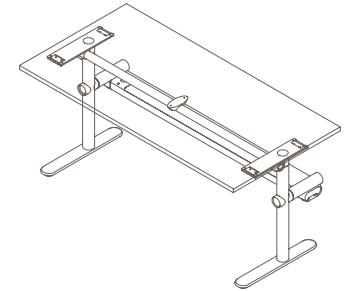
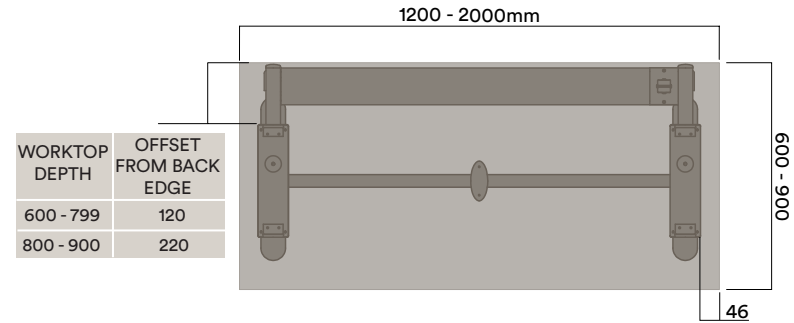

WORKTOP DEPTH	FRONT EDGE TO LEG
600	310
700	410
800	410
900	510

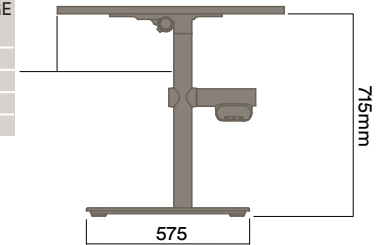

SRF-1002 2pax

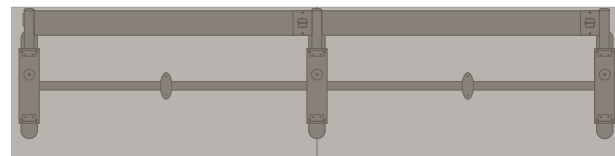

SRF-1003 3pax

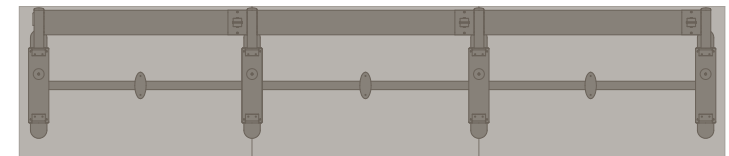

Glide Adjustment

Plus or minus 5mm

Maximum inc. worktop	100kg
Maximum Point Load	30kg
Seats	1-3

Fixed Single Sided

Materials Information

Leg & Foot Finish

Powdercoat Steel Leg & Foot

- a. Noir
- b. Blanc

Frame Finish

Powdercoat Steel

- a. Noir
- b. Blanc

Glide Adjustment

Plus or minus 5mm

Maximum inc. worktop 100kg
 Maximum Point Load 30kg
 Seats 1

SRF-1090 1pax

90deg

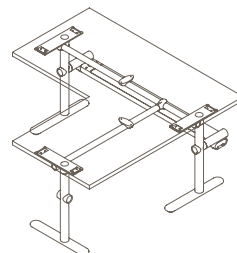
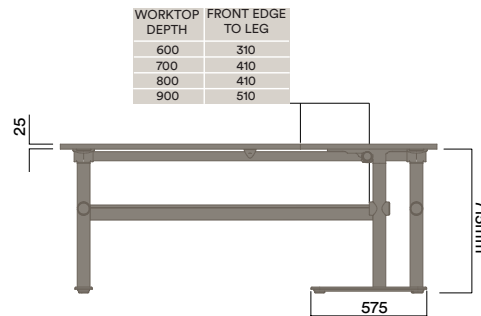
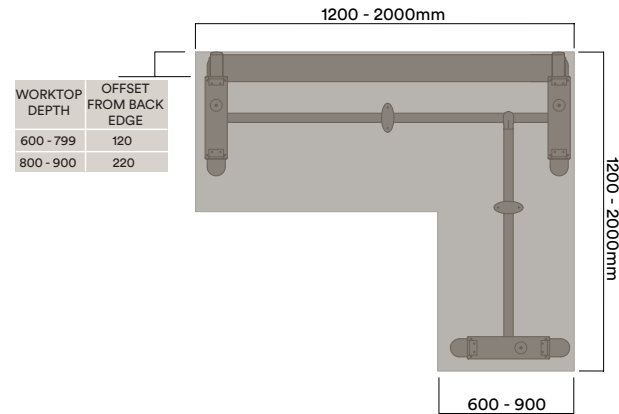

SRF-1120 1pax

120deg

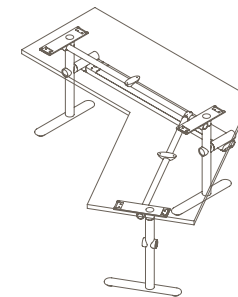
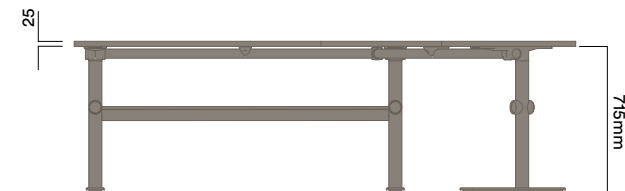
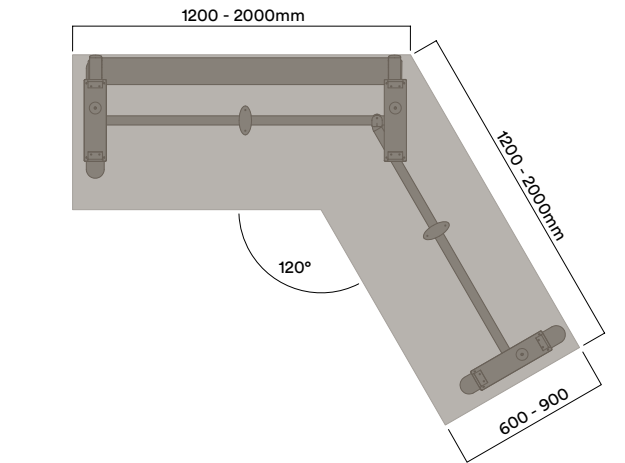

Fixed Double Sided

Materials Information

Leg & Foot Finish

Powdercoat Steel Leg & Foot

- a. Noir
- b. Blanc

Frame Finish

Powdercoat Steel

- a. Noir
- b. Blanc

SRF-2002 2pax

H-Frame

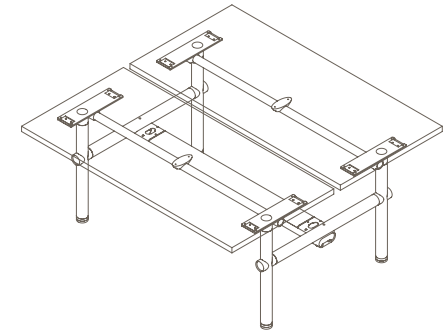
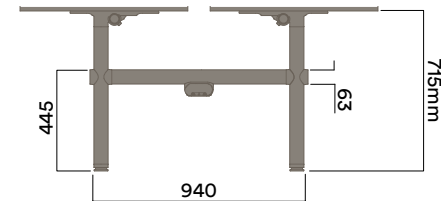
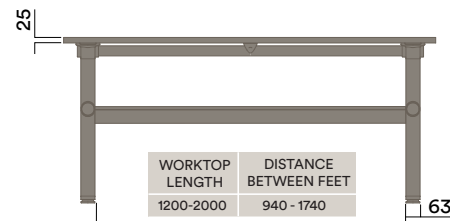
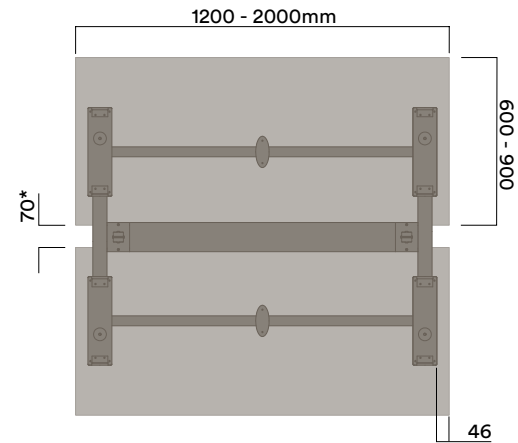

SRF-2004 4 pax

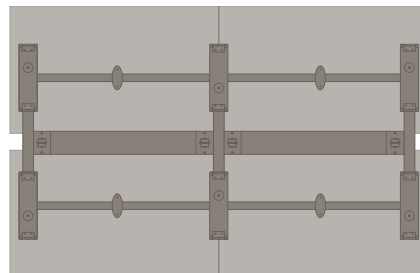

SRF-2006 6 pax

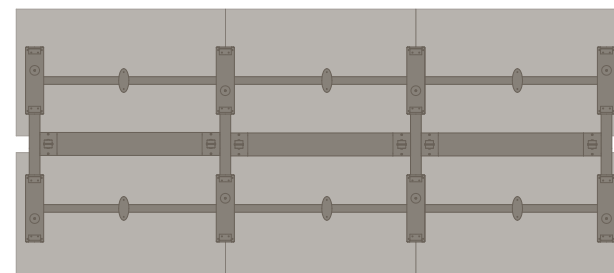

Glide Adjustment

Plus 85mm
Minus 5mm

Maximum inc. worktop 100kg
Maximum Point Load 30kg
Seats 2-6

*100mm gap required when using rear mounted screens

Fixed Double Sided

Materials Information

Leg & Foot Finish

Powdercoat Steel Leg & Foot

- a. Noir
- b. Blanc

Frame Finish

Powdercoat Steel

- a. Noir
- b. Blanc

Glide Adjustment

Plus 90mm

Minus 5mm

Maximum inc. worktop 100kg

Maximum Point Load 30kg

Seats 3-4

***100mm gap required when using rear mounted screens**

SRF-3120 3pax

120deg H-Frame

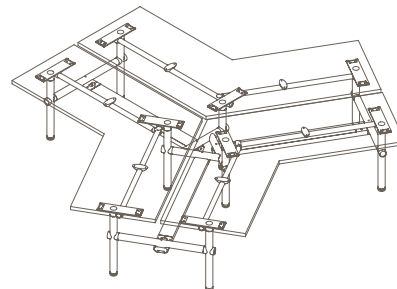
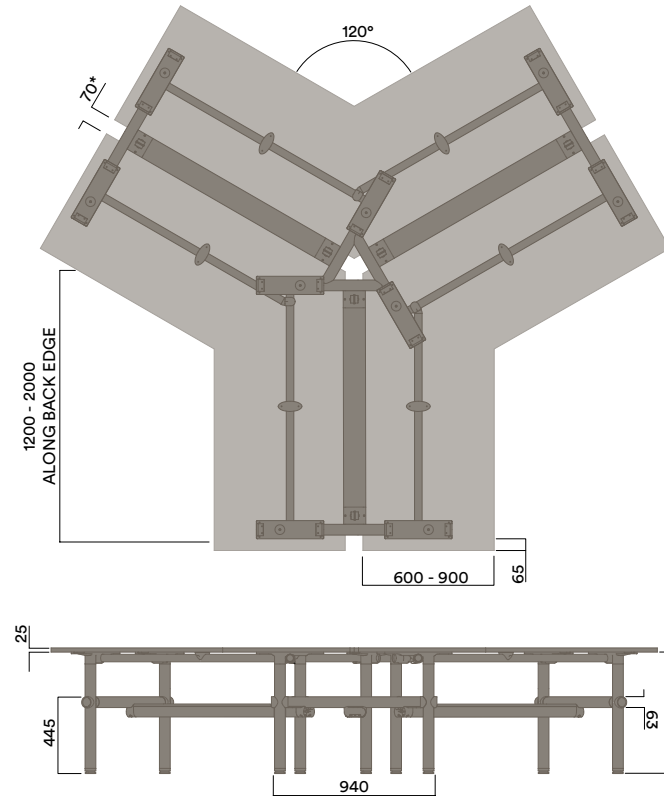

SRF-4090 4pax

90deg H-Frame

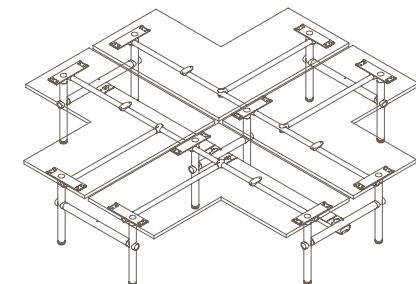
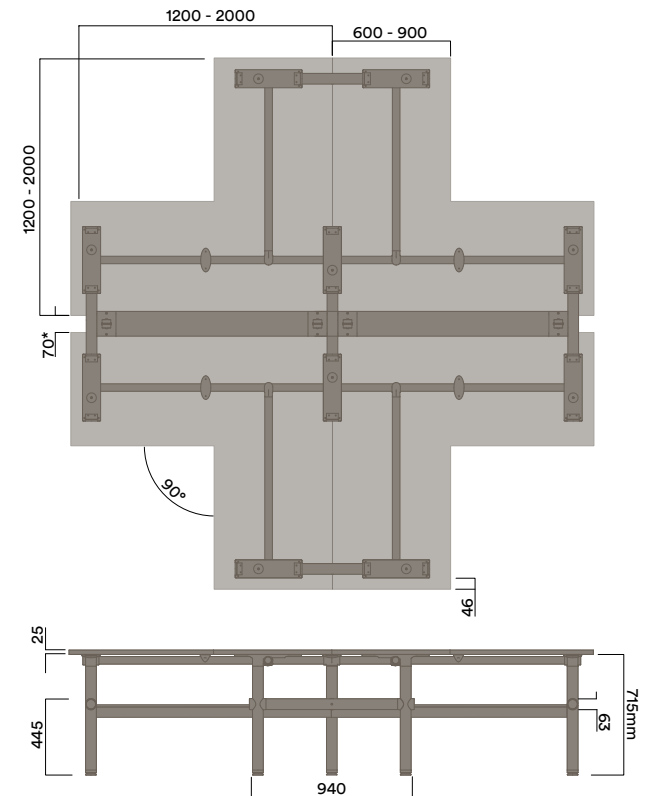

Fixed Double Sided

Materials Information

Leg & Foot Finish

Powdercoat Steel Leg & Foot

- a. Noir
- b. Blanc

Frame Finish

Powdercoat Steel

- a. Noir
- b. Blanc

Glide Adjustment

Plus 90mm

Minus 5mm

Maximum inc. worktop 100kg

Maximum Point Load 30kg

Seats 3-4

***100mm gap required when using rear mounted screens**

SRF-4090-24 4pax

90deg H-Frame

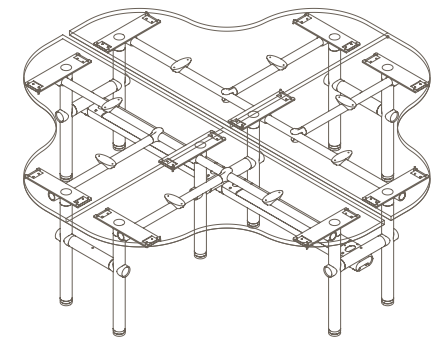
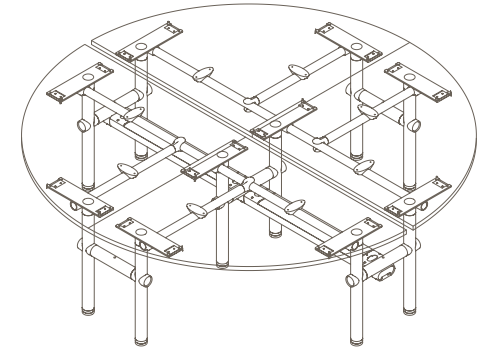
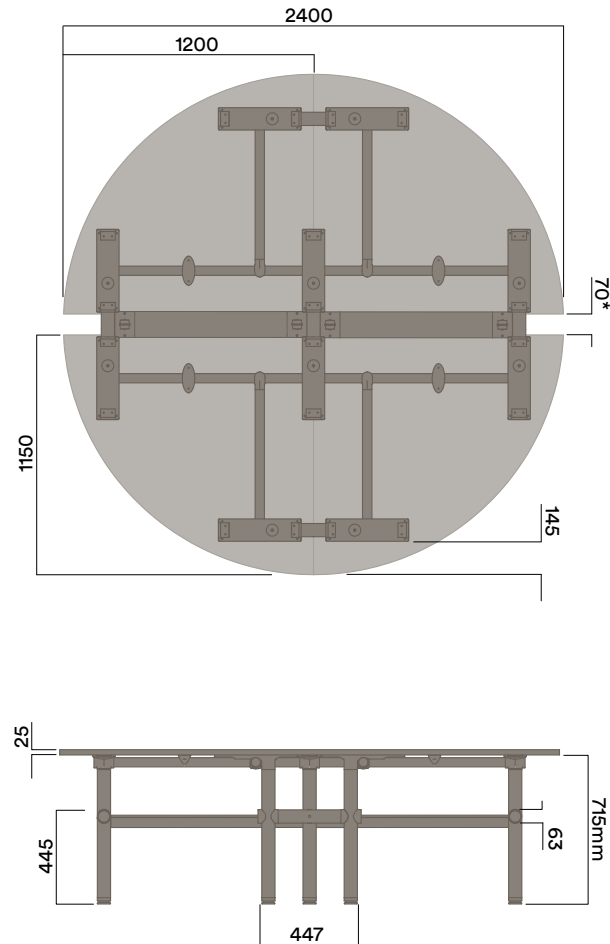

Accessories

Cable Management

Materials Information

Cable Tray Body

Powdercoat Aluminium

- a. Noir
- b. Blanc

Cable Tray Lid

Powdercoat Aluminium Extrusion

- a. Noir
- b. Blanc

Cable Tray End Caps

Plastic

- a. Noir
- b. Blanc

WSA-1100 Series

Single Sided Cable Tray

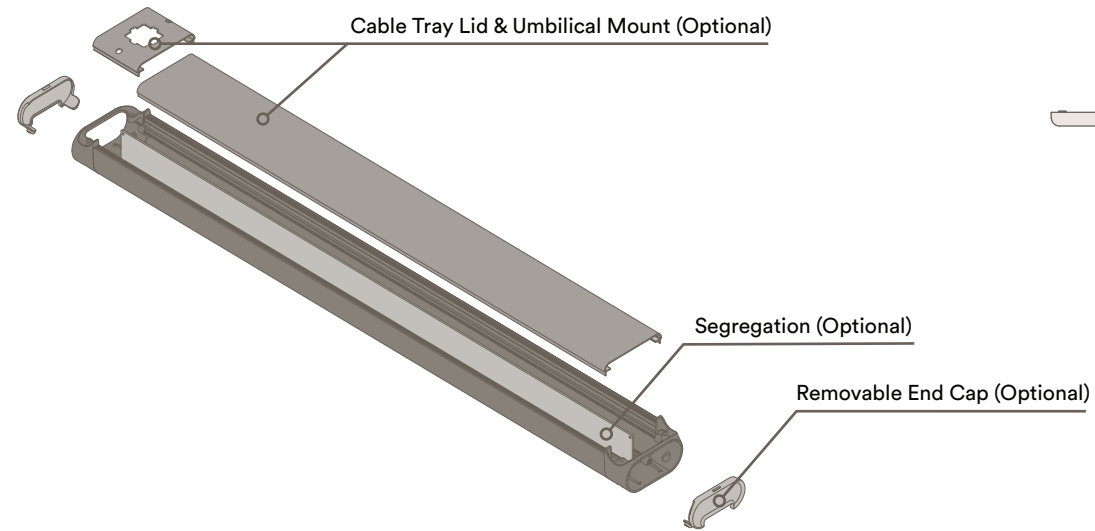

WSA-2000 Series

Double Sided Cable Tray

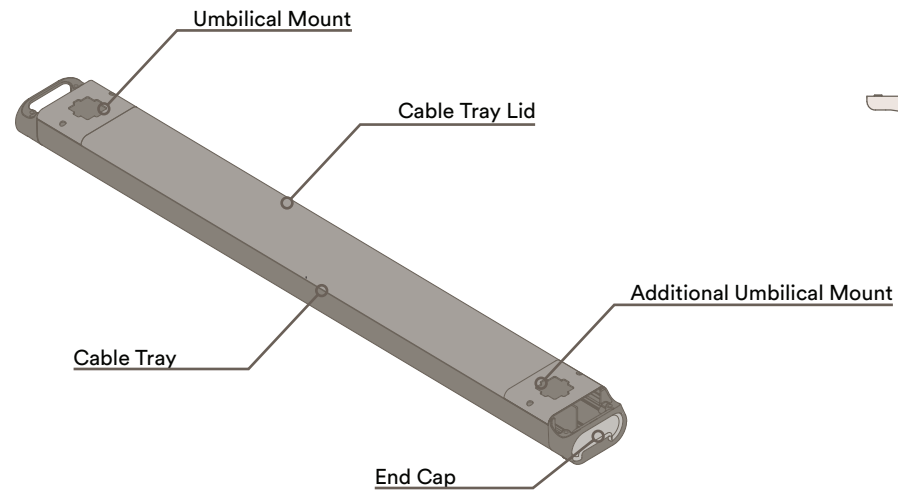

Accessories

Cable Management

Materials Information

WSA-5010 Series

Cable Tray Bridge

175-250mm

Cable Tray Bridge Body

Powdercoat Aluminium

- a. Noir
- b. Blanc

Cable Tray Bridge Lid

Powdercoat Aluminium Extrusion

- a. Noir
- b. Blanc

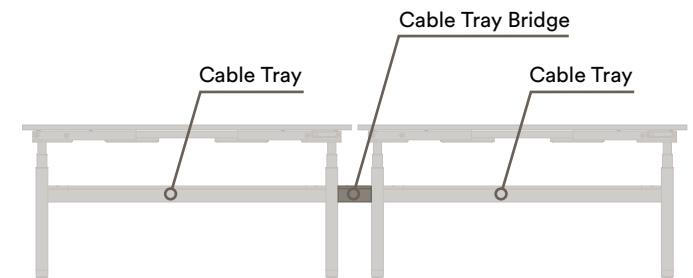
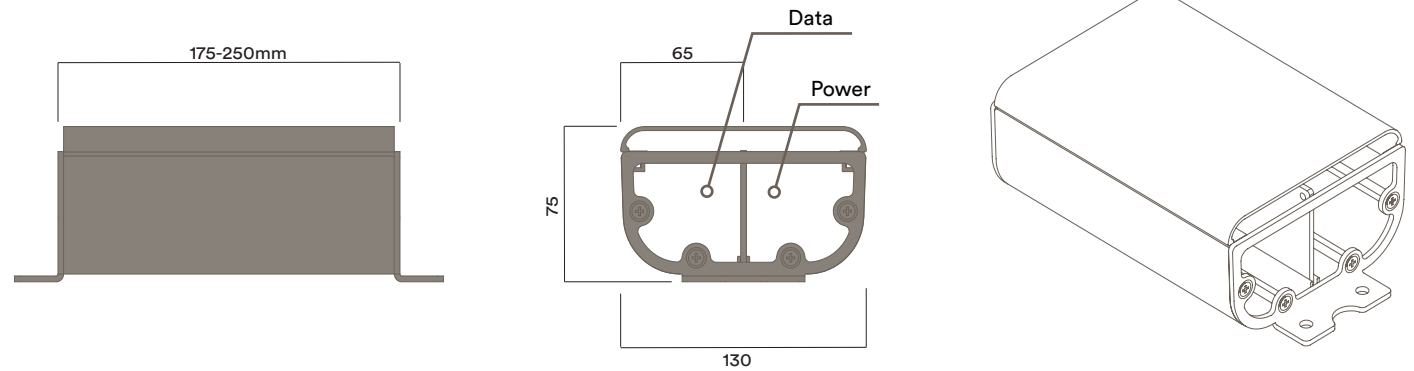

Accessories

Cable Management / Cross-Beam Accessory Rail

Materials Information

Fabric Umbilical

Fabric

- a. Light Grey

Cross-Beam Accessory Rail

Powdercoat Aluminium Cross-Beam

- a. Noir - to match frame
- b. Blanc - to match frame

WSA-5002

Cable Umbilical

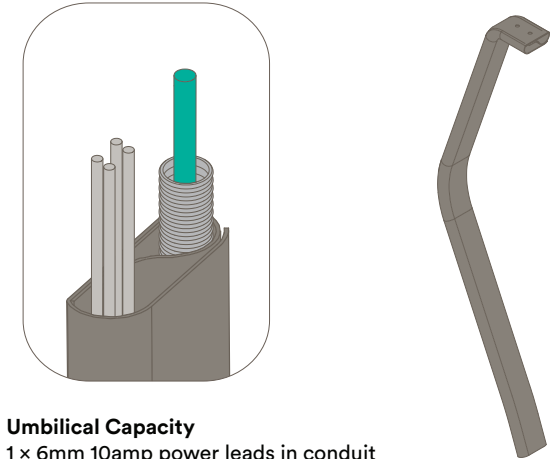
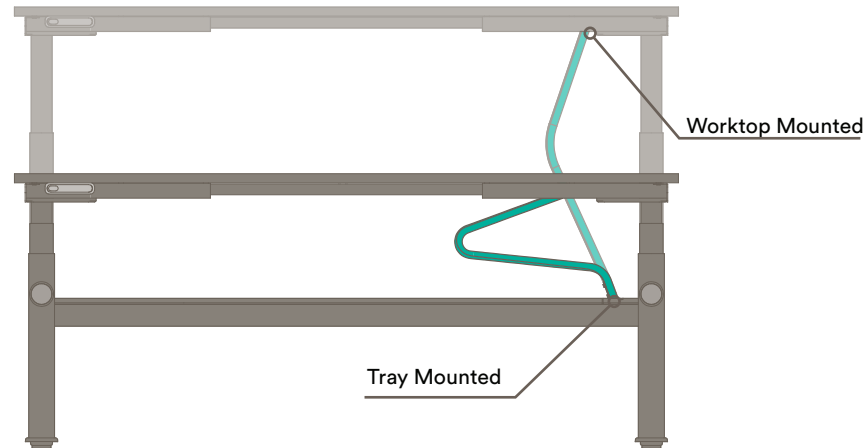

Umbilical Capacity

1 × 6mm 10amp power leads in conduit
4 × 6mm Cat 4 / Cat 6 data cables

SRA-5100

Cross-Beam Accessory Rail

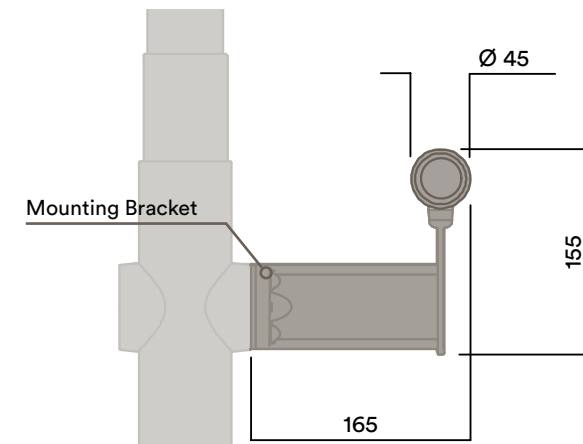
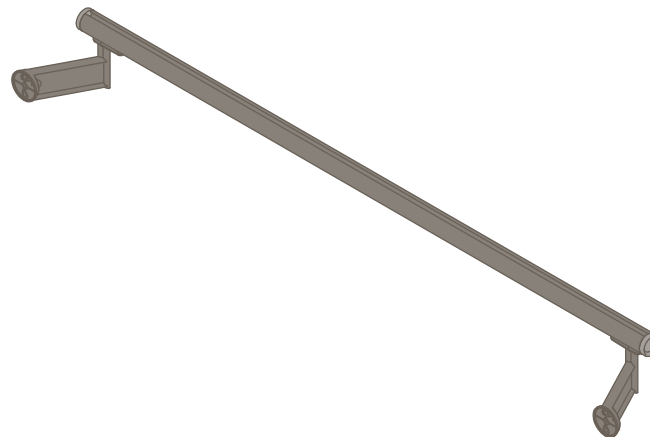

***Additional Frame Cross-Beam Accessory Rail**
Optional for Electric Single Sided 1200-2100mm WP

Optional for Electric 90/120deg 1400-1800mm WP
Required for Electric 90/120deg 1801-2100mm WP

Accessory Rail not required for Electric Single Sided
if Cable tray is fitted.

Accessories

Power Pocket

Materials Information

Power Pocket Bracket

Powdercoat Steel

a. Noir

Fabric Cable Pocket

Fabric

a. Light Grey

Power options for different countries available:

- a. 4 x Power & 2 x Data (AUS)
- b. 6 x Power (AUS)
- c. 4 x Power & 2 x Data (UK)
- d. 6 x Power (UK)

WSA-5003

Power Pocket

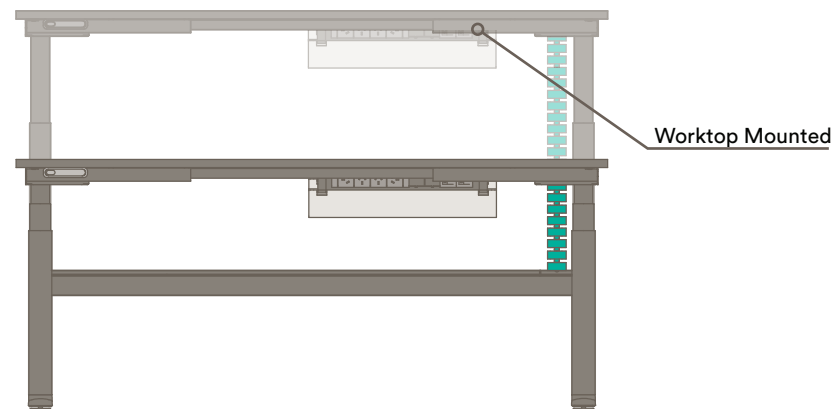
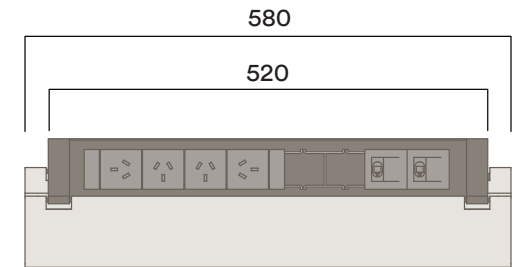
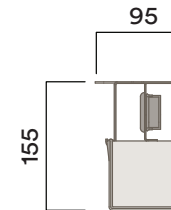
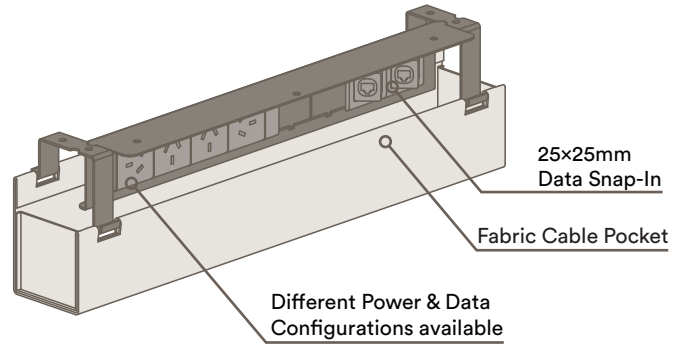

Power & Data Configurations:

a. Australia 4 x GPO & 2 x Data

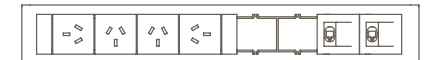

b. Australia 6 x GPO

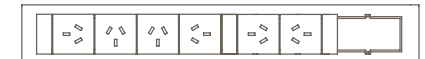

c. UK 4 x GPO & 2 x Data

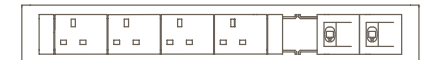

d. UK 6 x GPO

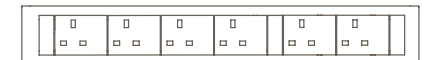

Accessories

Power Modesty

Materials Information

Power Pocket Bracket

Powdercoat Steel

a. Noir

Fabric Cable Modesty

Fabric

a. Light Grey

Power options for different countries available:

- a. 4 x Power & 2 x Data (AUS)
- b. 6 x Power (AUS)
- c. 4 x Power & 2 x Data (UK)
- d. 6 x Power (UK)

WSA-5004

Power Modesty - Small

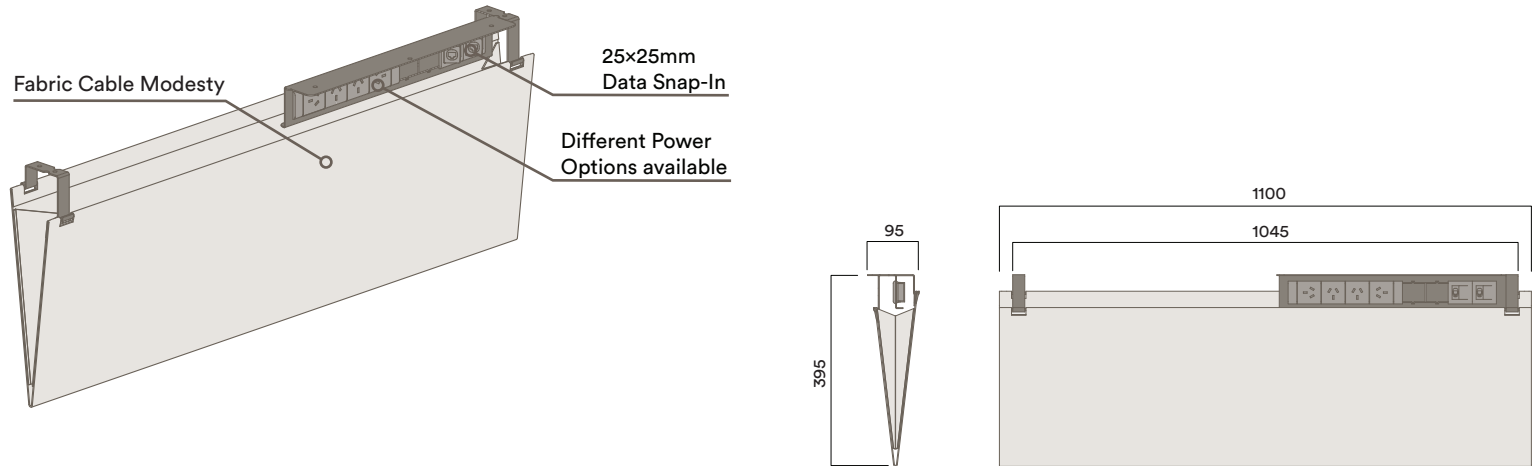

WSA-5005

Power Modesty - Large

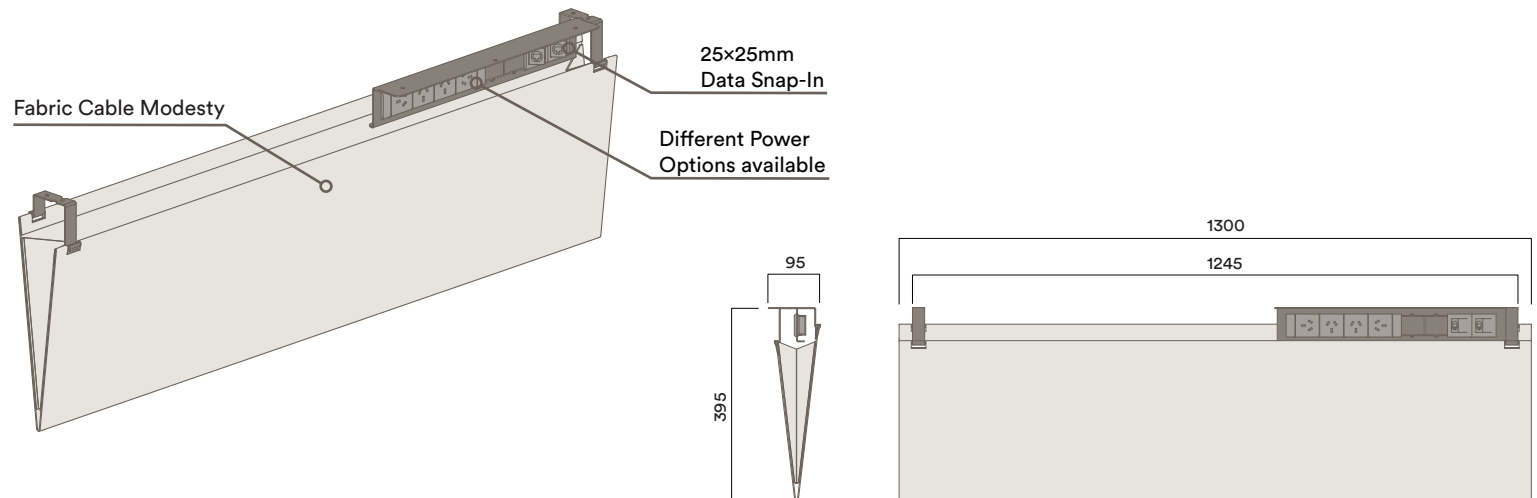

Accessories

Framed Acoustic Screens

Materials Information

Framed Acoustic Screen

PET Panel

- a. Light Grey
- b. Dark Grey
- c. Upholstered -
(Customer Supplied Fabric)

Screen Frame

Powdercoat Aluminium Screen Mount and Extrusion

- a. Noir
- b. Blanc

Acoustic Screen

PET Screen Panel

- a. Light Grey
- b. Dark Grey

Screen Mounts

Powdercoat Aluminium Screen Mount

- a. Noir
- b. Blanc

**Screen Mounting Method

Slide-on option available

WSA-4100 Series

Worktop Mounted Framed Acoustic Screen

WORKTOP LENGTH*	SCREEN LENGTH
1200	1150
1500	1450
1600	1550
1800	1750
2000	1950

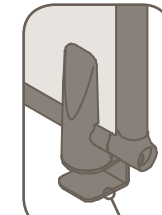
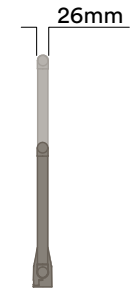
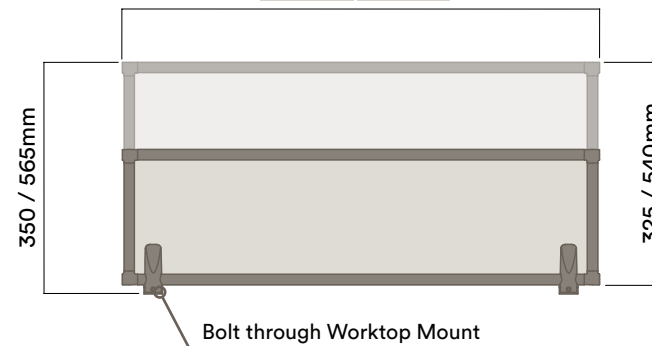

Slide-on Worktop Bracket Option

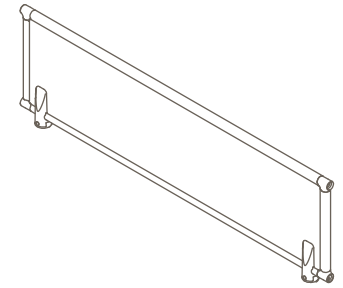

WSA-4100 Series

Central Mounted Framed Acoustic Screen

WORKTOP LENGTH*	SCREEN LENGTH
1200	1150
1500	1450
1600	1550
1800	1750
2000	1950

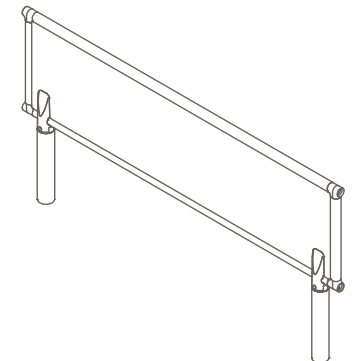
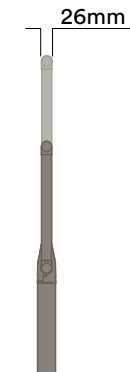
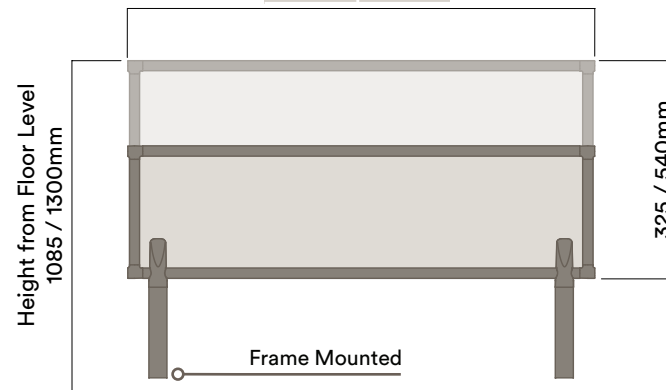

Accessories

Frameless Upholstered Screens

Materials Information

WSA-4300 Series

Worktop Mounted Upholstered Screen

Upholstered Screen

Fabric

- a. Upholstered - (Customer Supplied Fabric)

Screen Mounts

Powdercoat Aluminium Screen Mount and Extrusion

- a. Noir
- b. Blanc

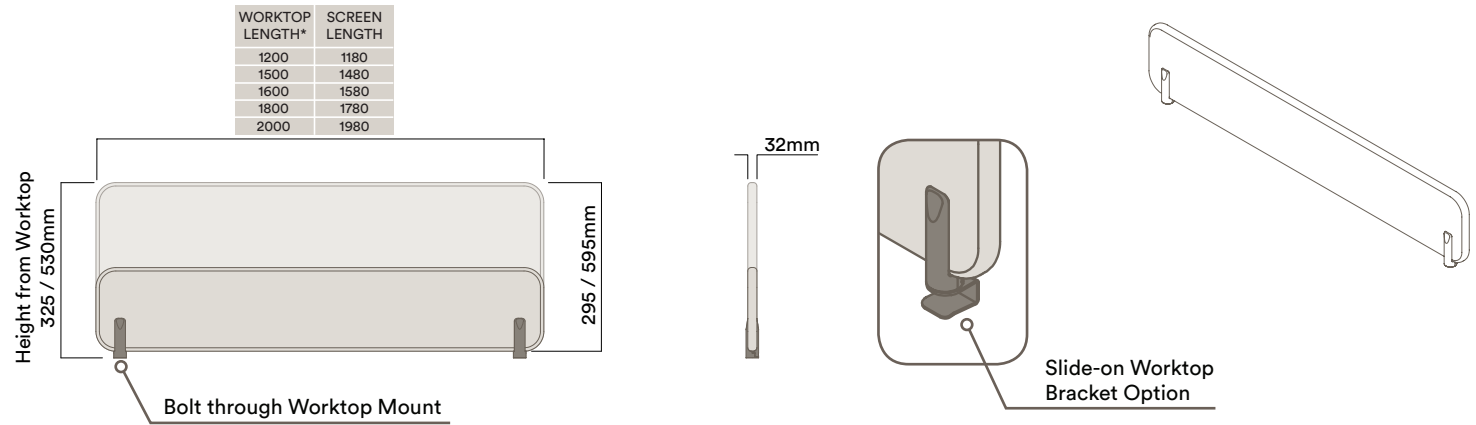

WSA-4300 Series

Central Mounted Upholstered Screen

***Note:**
Shown sizes are for rectangular Worktops only.
For screens to suit 90°, 120° & clusters - please consult your Thinkingworks representative.

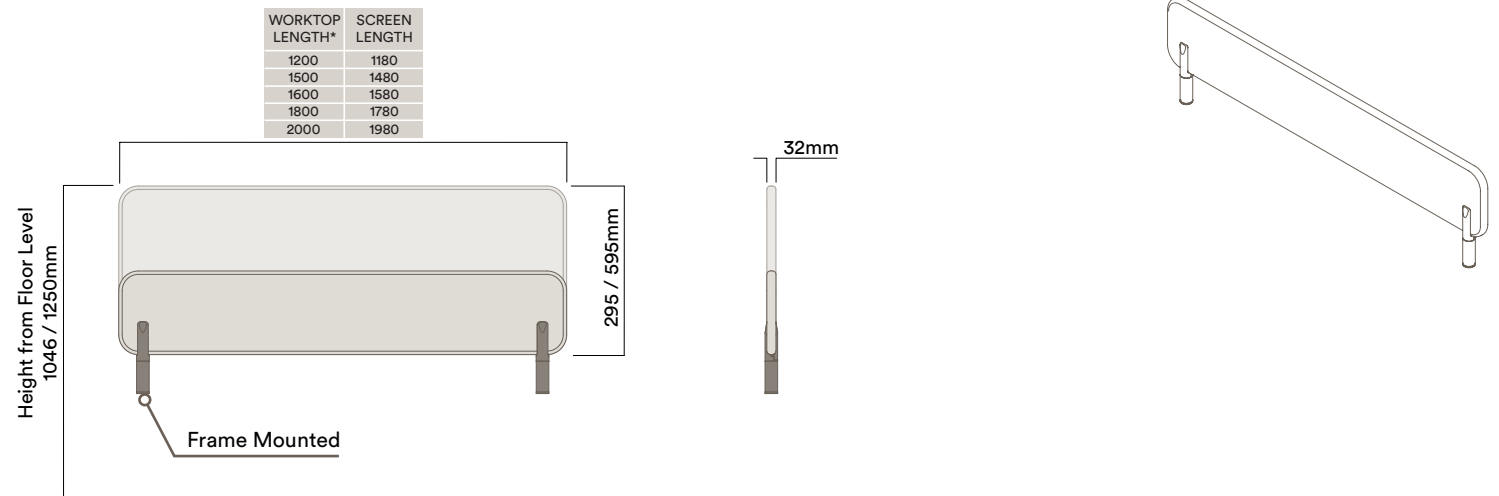

Accessories

PET Acoustic Screens

Materials Information

Acoustic Screen

PET Screen Panel

- a. Light Grey
- b. Dark Grey

Screen Mounts

Powdercoat Aluminium Screen Mount and Extrusion

- a. Noir
- b. Blanc

WSA-4000 Series

Worktop Mounted Acoustic PET Screen

WORKTOP LENGTH*	SCREEN LENGTH
1200	1100
1500	1400
1600	1500
1800	1700
2000	1900

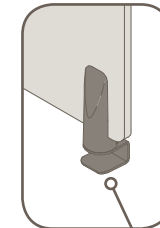
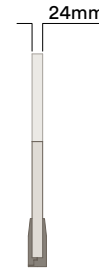
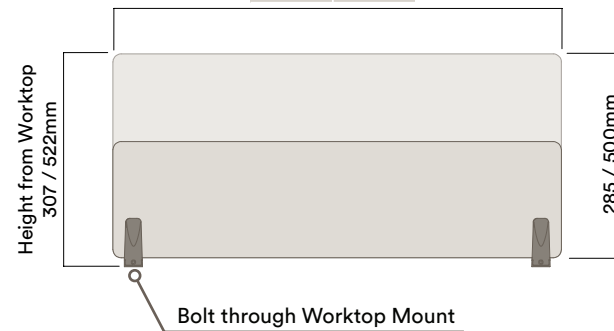

Slide-on Worktop Bracket Option

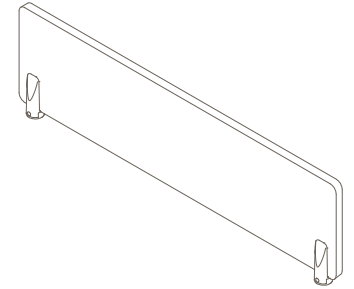

WSA-4000 Series

Central Mounted Acoustic PET Screen

WORKTOP LENGTH*	SCREEN LENGTH
1200	1100
1500	1400
1600	1500
1800	1700
2000	1900

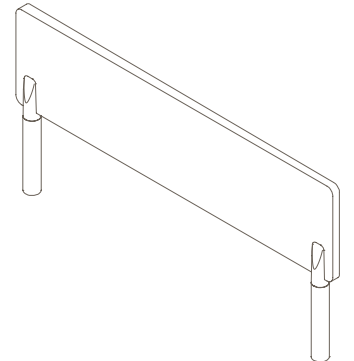
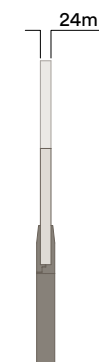
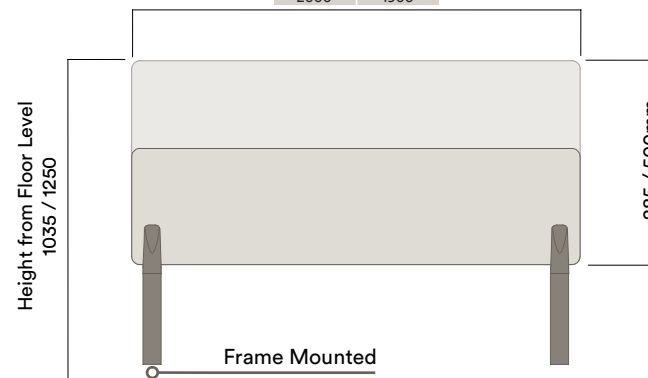

Accessories

PET Acoustic Screens

Materials Information

WSA-4000 Series

Worktop Mounted Acoustic PET Screen

Acoustic Screen

PET Screen Panel

- a. Light Grey
- b. Dark Grey

Screen Mounts

Powdercoat Aluminium Screen Mount and Extrusion

- a. Noir
- b. Blanc

WORKTOP LENGTH*	SCREEN LENGTH
1200	1100
1500	1400
1600	1500
1800	1700
2000	1900

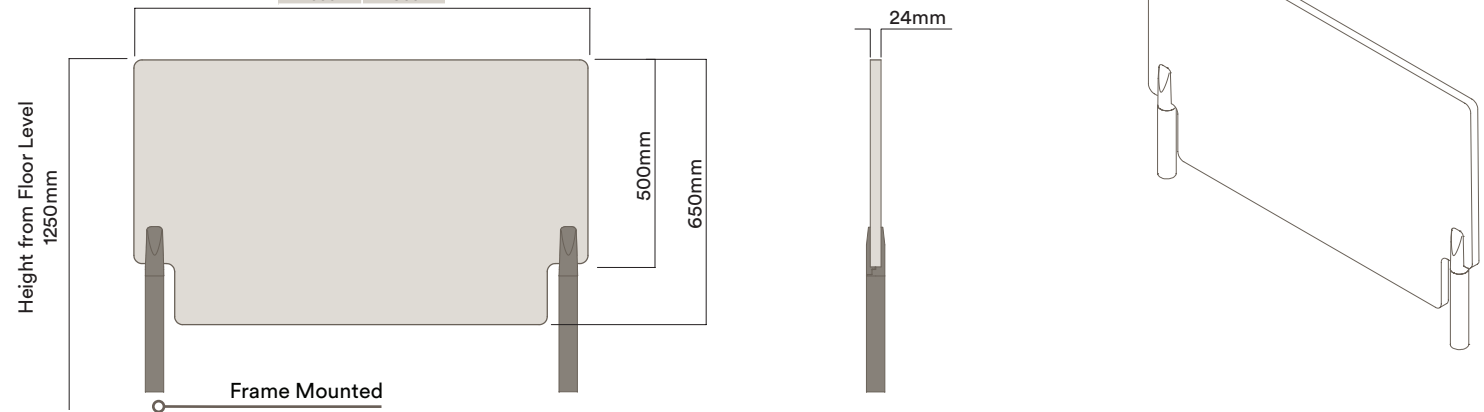

Accessories

PET Acoustic Screens

Materials Information

Acoustic Screen

PET Panel

- a. Light Grey
- b. Dark Grey

Screen Mounts

Powdercoat Steel Screen Mount

- a. Noir
- b. Blanc

WSA-4060 Series

Rear Mounted Acoustic Screen & Modesty - Single sided

WORKTOP LENGTH*	SCREEN LENGTH
1200	1100
1500	1400
1600	1500
1800	1700
2000	1900

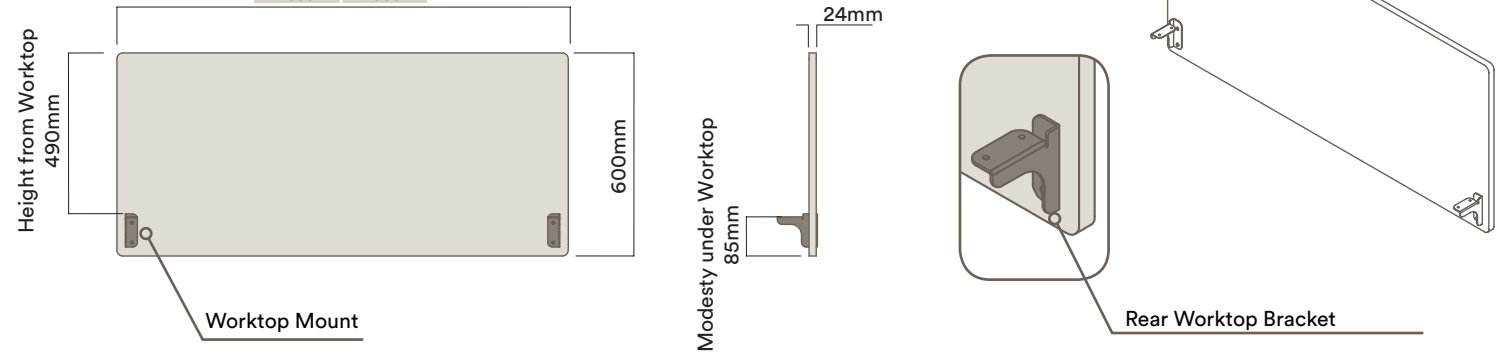

WSA-4060 Series

Rear Mounted Acoustic Screen & Modesty - Double sided

WORKTOP LENGTH*	SCREEN LENGTH
1200	1100
1500	1400
1600	1500
1800	1700
2000	1900

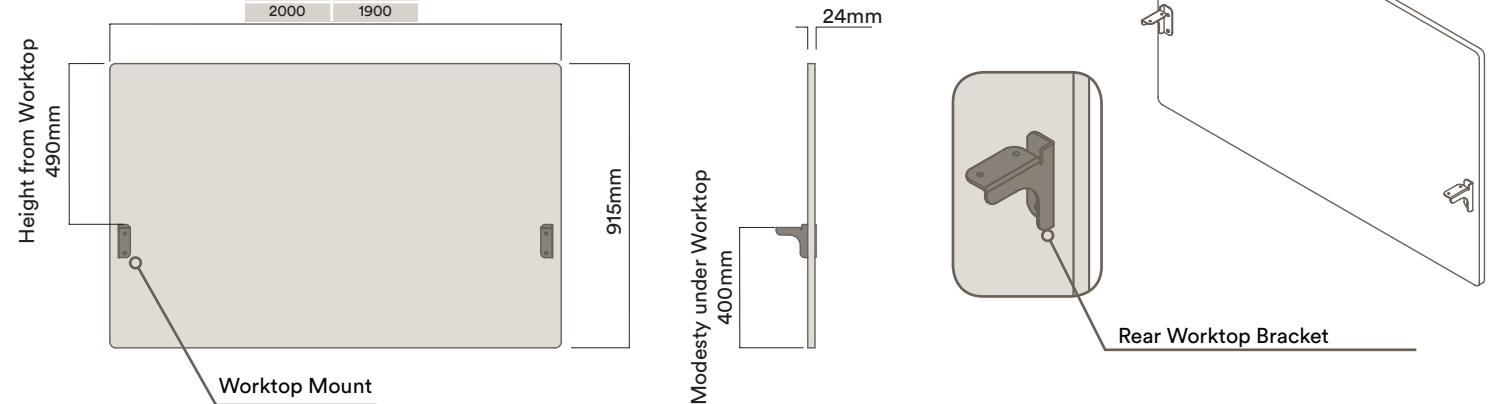

Accessories

Frame Mounted Cable Cover

Materials Information

WSA-5006 / 5007 / 5008

Frame Mounted Cable Cover

Cable Cover

Powdercoat Steel

a. Noir

Available in different lengths:

a. 800mm

b. 1000mm

c. 1350mm

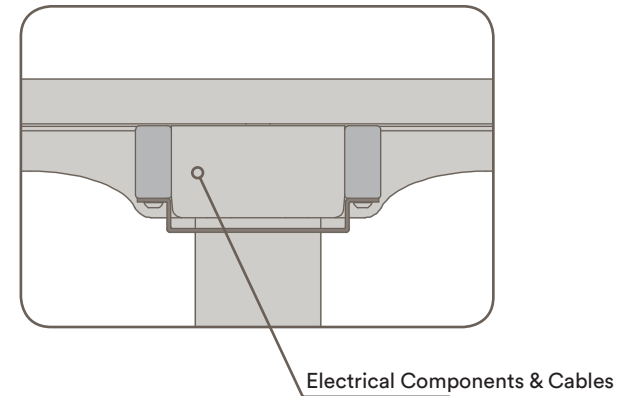
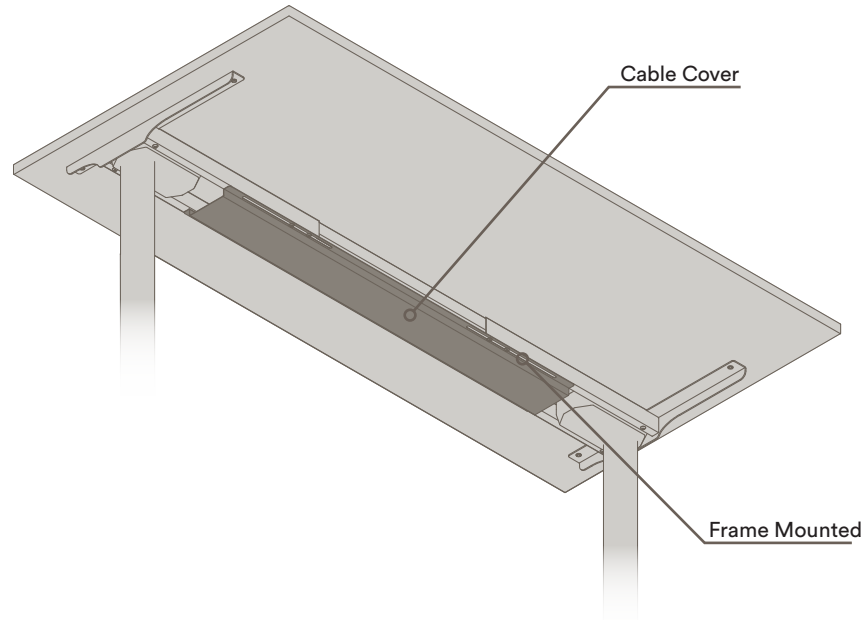

WORKTOP LENGTH*	COVER LENGTH
1200	800
1500	1000
1600	1000
1800	1350
2000	1350

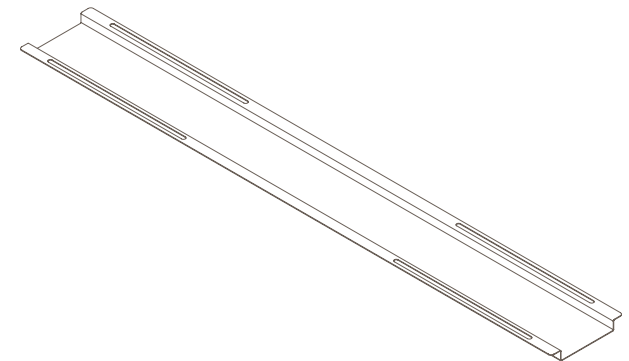
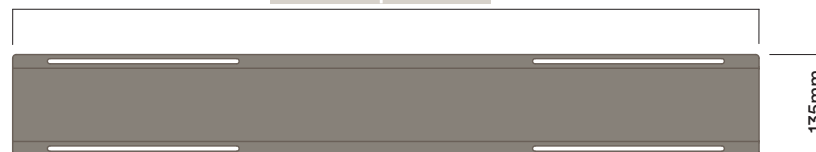

Electric Safety Features

Impact Stop

- Impact Stop system minimises damage to Electric Height Adjustable frames from contact with objects obstructing the path of movement
- Impact Stop initiates while frame is lowering or raising, when 1 second of resistance from an obstruction is detected.
- When resistance is detected, desk will automatically stop then move 50mm in opposite direction in order to clear obstruction.

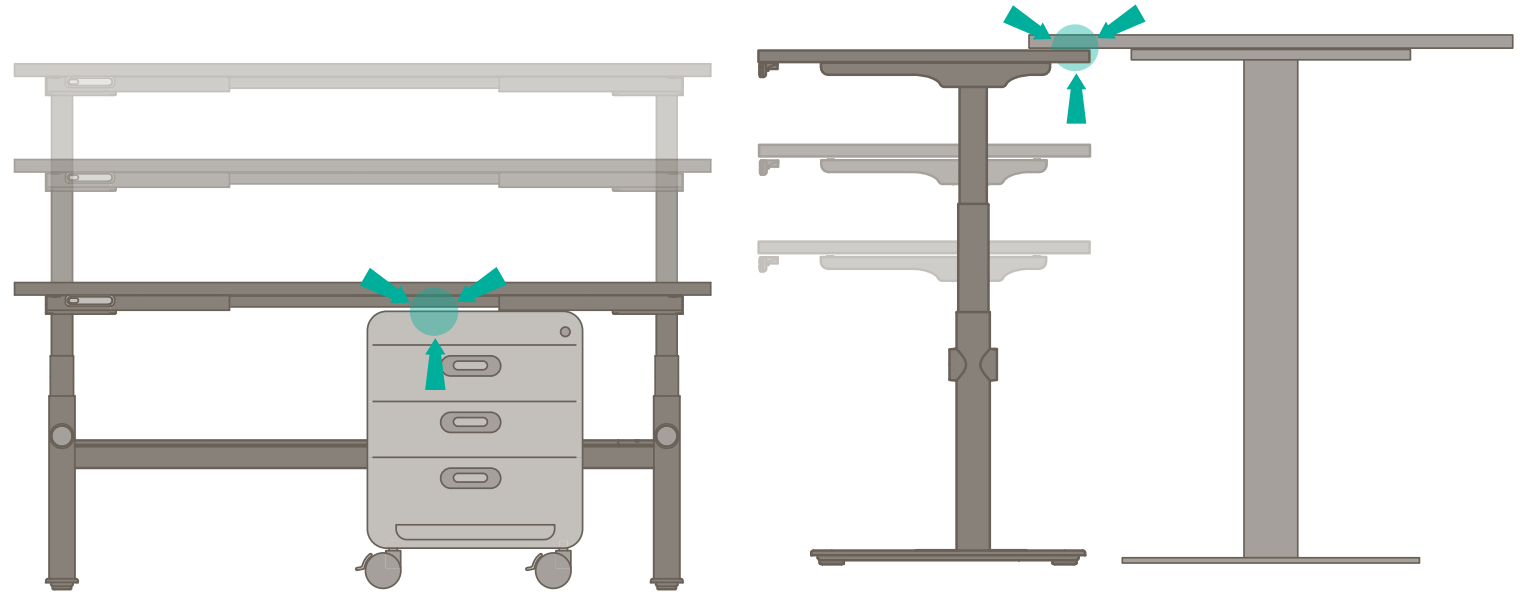



Specification

If you would like a sample set of any of our finishes, please call us on 61 (0)2 9726 7177 or e-mail at sales@thinkingw.com.

Due to our policy of continuous product development, specifications and finishes may change without prior notice.

Sustainability Policy

We realise the importance of responsible business practices and have in place numerous product and company sustainability certifications. We would encourage you to download our annual Sustainability Report from the Thinking Works website to get a full overview of our sustainability program.

Thinking Works
© Copyright 2020
All right reserved

Thinking Works
25 Helles Avenue
Moorebank
New South Wales 2170

www.thinkingw.com
61 (0)2 9726 7177
sales@thinkingw.com