



Jojo

Specification Guide

Jojo

The Ultimate Flexible Table Solution.

The Jojo Electric Folding Table combines the ergonomic benefits of height adjustable desking with the mobility of a folding frame.

Jojo uses a rechargeable battery to activate height adjustment, which promotes agility within the workplace.

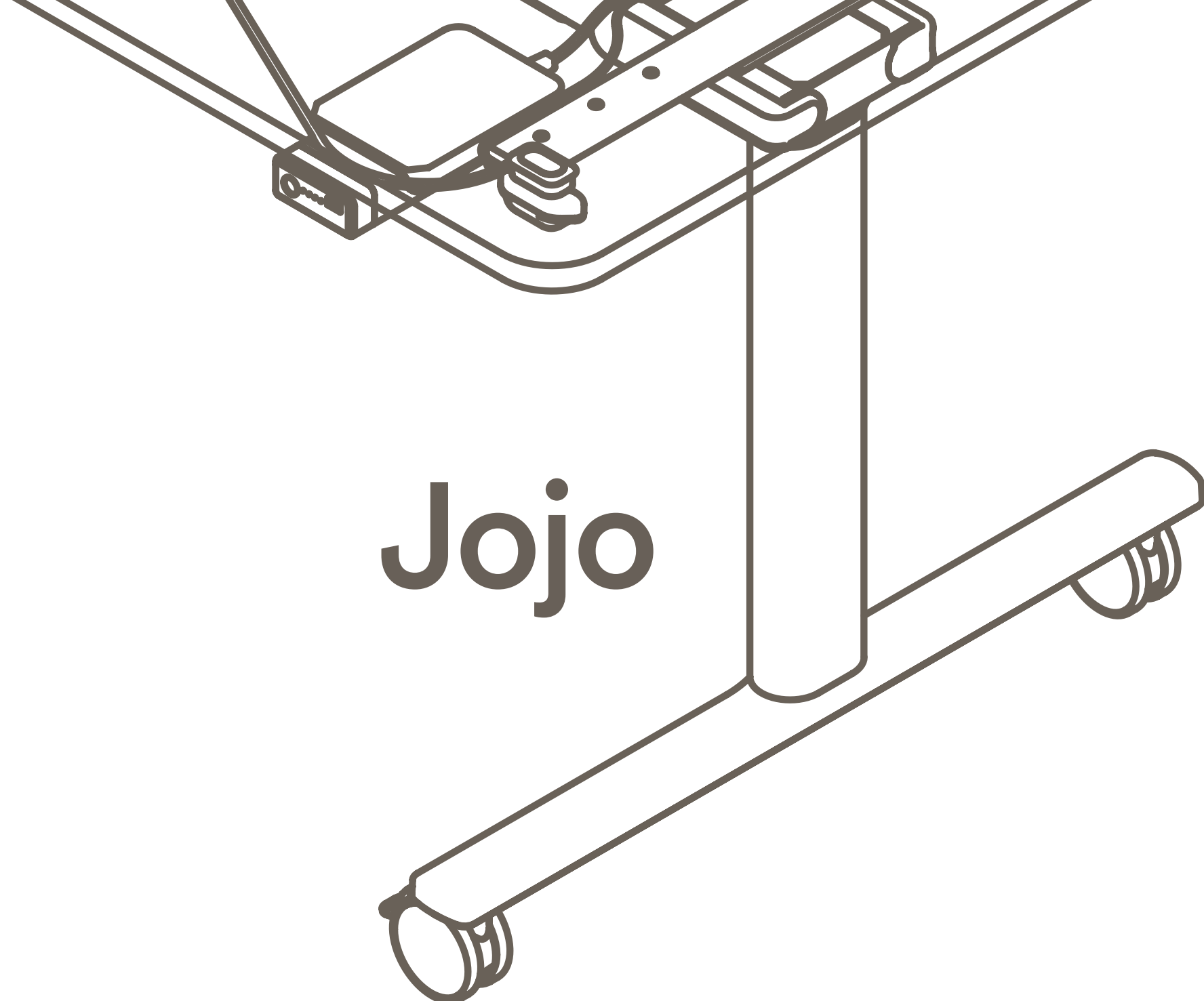

Jojo

Jojo Finishes

1. Frame Powdercoat

All steel frame is available in Noir and Blanc powdercoat.

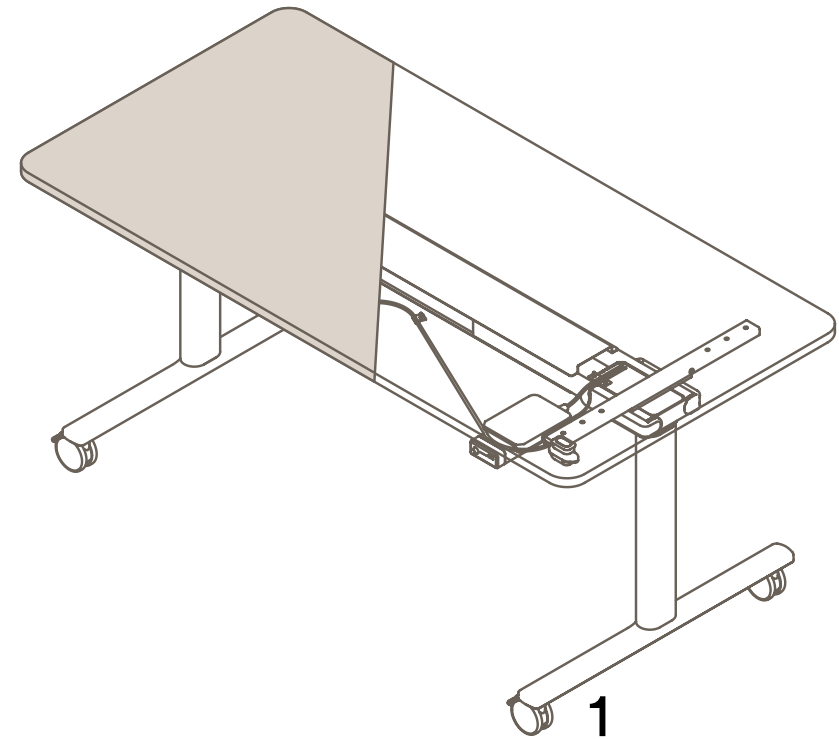

Colours are representative only, please check with your Thinking Works consultant to view samples of any specific colour.

Jojo Features

Dimensions

Minimum Height 710mm
Maximum Height 1330mm
(Dimensions to underside of worktop)

Weight Capacity 35kg Worktop

(Maximum Point Load 30kg)

Functions

- Soft touch silicon handset with up + down control
- Rechargeable battery system for wireless operation
- Built-in Impact Stop Function
- 3 Stage lifting Column with Spindle Drive
- Travel Speed = 35mm/Second
- Noise <50dB
- Castor feet for office mobility

Battery System

- Lithium Ion battery pack with 2.2AH capacity
- 40 up/down cycles from a charged battery
- 4 LED indicator shows remaining charge
- Audible “beep” when battery needs charging
- Worktop mounted for insertion and removal
- USB port for charging mobile phones
- Battery standby power consumption 0.1W
- 5 hour re-charging time

Warranty

Electric Frame 10yrs
Electrical Components 5yrs

Country of Origin

Australia

For additional Technical Information, please check with your local Thinking Works consultant.

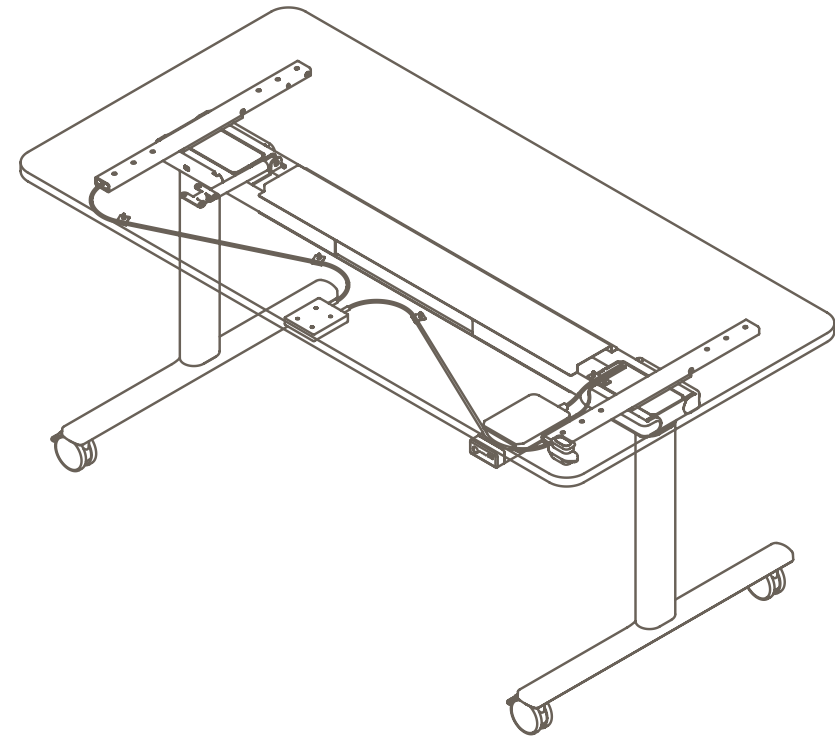

Worktop screws are supplied for securing the tabletop to the table base. They are provided as a general recommendation and must be assessed for compatibility with the specific tabletop substrate material and thickness. It is the responsibility of the installation team to determine whether the supplied screws are suitable or should be replaced with fasteners more suitable for the specified worktop substrate and thickness.

Jojo

Electric Height Adjustable + Folding

Materials Information

Frame Finish

Powdercoat Steel

- a. Noir
- b. Blanc

Castor Finish

- a. Black
- b. White

Control Box & Handset Finish

- a. Black

Operating Noise Level

<50Db

Height Range

710mm to 1330mm to underside of worktop

Travel Speed

35/mm per second

Battery System

40 up/down cycles from a charged battery

Handset

Soft touch silicon handset with up + down control

Maximum Worktop 35kg
 Maximum Point Load 30kg

Notes:

* Worktops 1200-1800mm long have 130mm overhang at ends of the table.

Worktops 1801-2000mm long have longer overhang at the ends of the table up to 230mm.

**Folded footprint of table is 750mm wide. Each additional stacked table adds 220mm.

JJE-1000

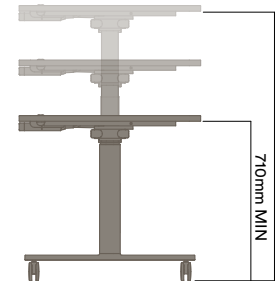
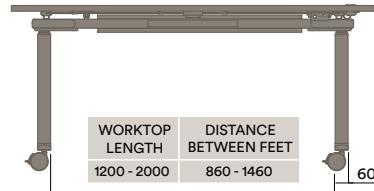
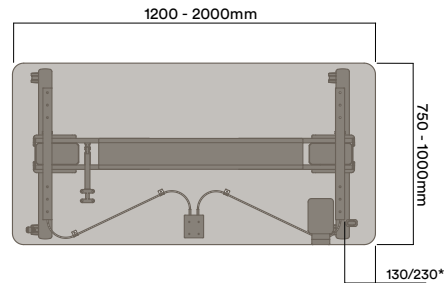

Worktop screws are supplied for securing the tabletop to the table base. They are provided as a general recommendation and must be assessed for compatibility with the specific tabletop substrate material and thickness. It is the responsibility of the installation team to determine whether the supplied screws are suitable or should be replaced with fasteners more suitable for the specified worktop substrate and thickness.

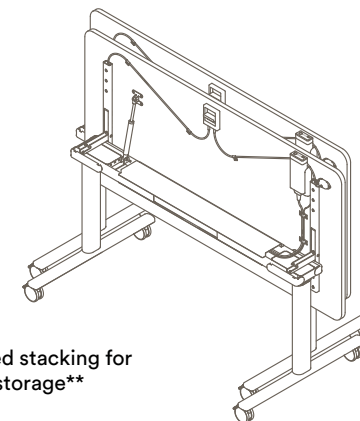
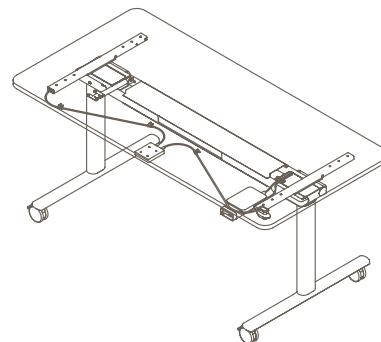
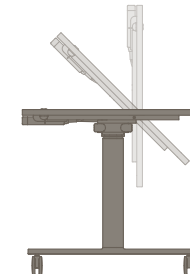

Nested stacking for easy storage**



Specification

If you would like a sample set of any of our finishes, please call us on 61 (0)2 9726 7177 or e-mail at sales@thinkingw.com.

Due to our policy of continuous product development, specifications and finishes may change without prior notice.

Sustainability

Our commitment to sustainability isn't driven by trends, it is guided by our belief that doing the right thing is the only way forward. From product certifications to responsible sourcing, we are committed to taking meaningful action across every part of our business. To learn more about our sustainability journey, visit the Thinking Works website or contact our Sustainability & ESG Manager using the details below.

Thinking Works
© Copyright 2026
All right reserved

Thinking Works
Warehouse 2B/M5 Industry Park
1 Moorebank Ave, Moorebank
New South Wales 2170
Australia

www.thinkingw.com
61 (0)2 9726 7177
sales@thinkingw.com